



*Users Manual*  
**Manual de Instrucciones**



**HOWARD**



**Rotavator**  
**HR7 / HR7 HD / HR9 / HR12**

# Rotavator

HR7 - HR7 HD - HR12

## CONTENTS

Safety precautions .....	10
Technical specifications .....	11
New machine .....	12
Attaching the Rotavator to the tractor .....	12
Rotor and blades .....	13
Lubrication and maintenance .....	13
Operating instructions .....	14
Operators check list .....	15
Warning and Danger signals .....	16
Parts list .....	41

We congratulate you for your purchase of a new HOWARD machine. It has been designed and manufactured for intensive use and for a long worklife. We recommend you read this manual thoroughly and pay strict attention to the instructions in it so the machine will provide optimum service and work will be done safely and efficiently

### Serial number

The serial number and model numbers are stamped on the identification plate attached to your Rotavator. For future reference, record the numbers below. Always quote them when ordering spare parts

**MODEL** .....

**SERIAL N.** .....

**DATE PURCHASED** .....

# Rotavator

HR7 - HR7 HD - HR12

## SAFETY PRECAUTIONS



**BE ALERT:** When you see this symbol on a Rotavator or in the instructions, it warns of a hazard which could lead to injury

### Before Use

- Ensure operators have read and are familiar with the instructions contained in this publication.
- Consult the tractor Manufacturer's Manual for instructions on mounting implements and safe working methods.
- Ensure the Rotavator is standing on firm, level ground with the praking prop in the lowered position.
- Make certain that all guards, covers, warning labels and safety devices are correctly fitted and operative.
- Ensure that the work area is clear of bystanders.
- Inspect the work area for obstructions which may constitute a hazard.
- Disengage all clutches and shift into neutral prior to starting the tractor engine.

### During use

- Observe all safe driving procedures such as reducing speed on slopes and sharp turns.
- Be alert for hidden obstructions, should an obstruction be struck, stop and check for damage to the Rotavator before proceeding.
- Avoid working on ground where there is a risk of the tractor overturning.
- Do not cultivate across the face of slopes.
- Avoid disengaging the tractor transmission before raising the Rotavator from the ground.

### After use

- Inspect the Rotavator for damage.
- Check that all bolts, nuts and fasteners are tight.
- Carry out lubrication and maintenance as detailed in this publication.
- Disengage the pto. drive when transporting the Rotavator.

### Always

- Wear substantial or safety footwear.
- Avoid loose clothing which may be caught in moving parts.
- Remove the tractor ignition key, before handling or repairing the machine.
- Wear gloves when handling worn implements or parts with sharp edges.
- Ensure the Rotavator is not operated by children or untrained persons.
- Use the Rotavator only for the purpose for which it was designed and tested, and in accordance with the instructions contained in this publication.
- Interpret "left" or "right" as left or right hand of the operator when sitting on the tractor seat and facing forward.



### NEVER:

- Touch any moving part of the Rotavator or parts which may be hot from operation.
- Check the levels whilst the Rotavator is running.
- Carry out adjustments or repairs to a mounted Rotavator unless the tractor engine is stopped and the Rotavator firmly supported or lowered to the ground.
- Leave the tractor seat unless the Rotavator is lowered, the PTO drive disengaged, the gear shift in neutral, the brake applied, the engine stopped and the ignition key removed.
- Climb onto the machine when it is in operation.

### PTO drive shaft guards

**HOWARD** products are supplied with non-rotating PTO drive shaft guards which must be correctly fitted and well maintained.

Before and after each use PTO driven implements should be examined to ensure the drive shaft rotates freely in the guards, the guards are undamaged, securely fitted, correctly seated on the shaft grooves and the restraining chains attached to the tractor and implement.

Should the guards be broken, damaged or badly fitted the implement must not be used until damaged parts have been replaced and/or bad fitting corrected.

Always ensure the guard tubes do not separate at the PTO drive shaft's longest working or transport length, or jam at it's shortest.

Avoid damage to guards when the PTO drive shaft is being connected or disconnected from the tractor by resting it on a support.

Never allow PTO drive shaft guards to fall into the implement or drop to the ground; damage will almost certainly occur.

Always ensure the sliding surfaces of the guard tubes are clean and the guard bearings lubricated.

When replacing worn or damaged sections of the guard, use special tools available from the makers.

Always follow the fitting, lubrication and maintenance instructions supplied by the makers of the PTO drive shaft guard.



**UNLESS CORRECTLY GUARDED PTO DRIVE SHAFTS CAN KILL**

# Rotavator

HR7 - HR7 HD - HR12

## TECHNICAL SPECIFICATIONS

Model	Speeds	Working Width cm/in	Number of blades	Total width cm	Weight Kg/lb	Tractor power HP	Rotor speed rpm
HR7-40	1	100/40	16	115/45	166/365	12-25	
HR7-50	1	130/50	20	140/55	182/400	18-30	
HR7-60	1	150/60	24	168/65	198/435	20-30	
HR7-40 HD	1	100/40	24	115/45	166/376	20-30	232
HR7-50 HD	1	130/50	30	140/55	182/415	22-32	
HR7-60 HD	1	150/60	36	168/65	198/455	25-35	
HR12-30	1	80/30	18	95/40	180/374	15-30	
HR12-35	1	90/35	21	107/43	193/385	15-30	
HR12-40	1	100/40	24	115/45	198/396	15-30	
HR12-45	1	115/45	27	130/50	203/407	20-35	230
HR12-50	1	130/50	30	140/55	208/418	25-35	
HR12-55	1	140/55	33	155/60	213/429	30-40	
HR12-60	1	150/60	36	168/65	218/451	35-40	

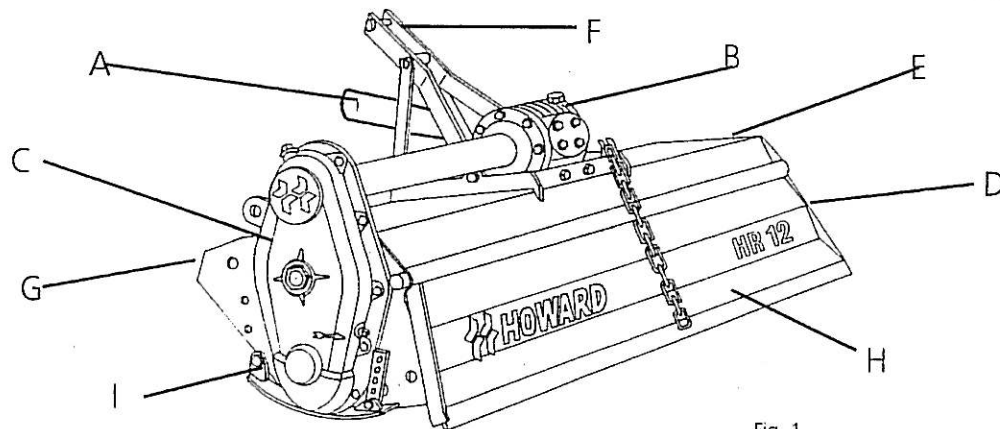

Fig. 1

## DESCRIPTION

Fig. 1 indicates assemblies referred to in the text of this manual which are named below:

- |                    |                        |
|--------------------|------------------------|
| A: PTO drive shaft | F: Top mast            |
| B: Gearbox         | G: Frame               |
| C: Side drive      | H: Trailing board      |
| D: Rotor           | I: Depth control skids |
| E: Hull            |                        |

HR7 is designed for 12 to 30 HP tractors with cat 0 linkage. HR7 HD and HR12 are designed for 15 to 35 HP tractors and for 15 to 40 HP tractors respectively with cat. I linkage. The drive is by a PTO shaft from a 540 rpm. The gearbox is single speed. The jackshaft transmits the power from the gearbox via the side chain in the models HR7 / HR7 HD or via the side gear train in the models HR12. An overload clutch provides protection for the transmission.

The normal tillage depth of 7 to 18 cm is regulated by the depth control skids. Rotavator are suitable for primary and secondary tillage, weed control and incorporating of material into most soil types..

# Rotavator

HR7 - HR7 HD - HR12

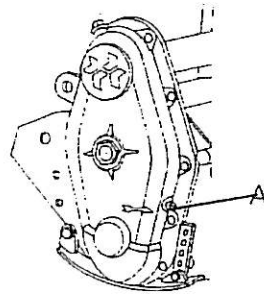

Fig. 2

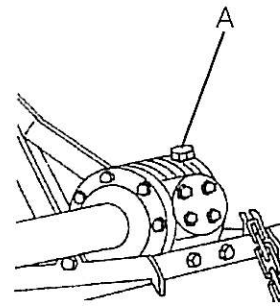

Fig. 3

## NEW MACHINE

### PTO shaft

For transport purposes, the PTO shaft is dismantled and must be refitted.

### Lubrication and general

With the machine standing level ensure the following preparatory work has been done:

1. The gearbox filled to the level plug (A) (fig. 2) Capacity: 1l. Use SAE 90 oil.
2. The gearbox filled up to the level mark in the inside rod (A) (fig. 3). Capacity 1 l. Use SAE 90 oil.
3. All oil and grease points as indicated on p. 17 (Lubrication)
4. All nuts and bolts tightened. (Re-tighten after first hour's work)



**SERIOUS DAMAGE CAN RESULT FROM FAILURE TO CARRY OUT THE ABOVE PROCEDURES**

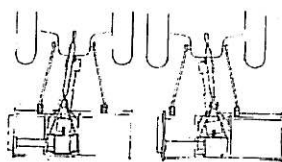

Fig. 4

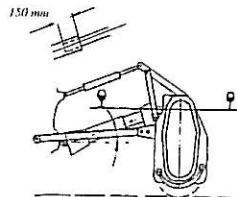

Fig. 5

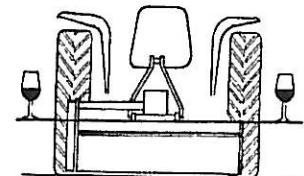

Fig. 6

## ATTACHING THE ROTAVATOR TO THE TRACTOR

All models have dual mounting position, i.e. central or offset to the right. Offset mounting is achieved by repositioning the lower link mounting brackets. (fig.4)

The PTO drive shaft must be set to a safe working length to ensure the male shaft does not "bottom" or separate from the female tube under all conditions of use and transport.

To determine the correct mounting position: with the Rotavator on a firm level surface the Depth Control equipment should be adjusted until the gearbox input shaft is horizontal (fig.5). Position the tractor at a distance from the Rotavator to give 150 mm (6") minimum engagement of the male half of the PTO drive shaft in the female tube when connected to the tractor. This establishes the safe working length of PTO drive shaft for connection to the tractor.

Position the tractor lower link ball joints in line with the mounting pins. Connect the tractor lower links. Fit the tractor upper link and secure. Attach the PTO drive shaft to the pressure plate by the studs and tighten the nuts. Attach the PTO drive shaft guard chains to the tractor and Rotavator.

Attach stabilizer bar or check chains to limit sway to 50 mm (2"). Adjust tractor linkage to level Rotavator laterally and longitudinally (fig. 5 and 6). Before engaging the tractor PTO, lift the Rotavator on the hydraulic lift linkage until the PTO drive shaft attains an angle of 40° and set the limit stop on the hydraulic lift control quadrant. (fig. 5)



**ATTENTION! : THE PTO DRIVE SHAFT ANGLE MUST NEVER EXCEED 40°.**

Finally check that during transport and use the PTO drive shaft does not "bottom" or separate and that the maximum angle of 40° is not exceeded. Should it not be possible to obtain the aforementioned setting with your tractor, SEEK ADVICE, it may be necessary to reduce the length of the PTO drive shaft by cutting.

# Rotavator

HR7 - HR7 HD - HR12

## Depth control

Fig. 7 illustrates how to adjust the depth control skids.

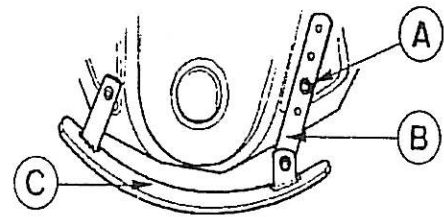

## ROTOR AND BLADES

HR7 / HR7 HD / HR12 Rotavators are fitted with original **HOWARD BLADES** model 665149/150. See **fig. 8** where the left blade is marked with X. Use always only **ORIGINAL HOWARD BLADES** and **HOWARD** blade bolts.

The blades must form a "scroll" pattern (**fig. 9**). This ensures that they enter the soil at regular intervals to even out the load on the transmission.

When replacing worn blades, remove one blade and fit the new one in its place before proceeding to the next. This will ensure that the blade "scroll" pattern is maintained.

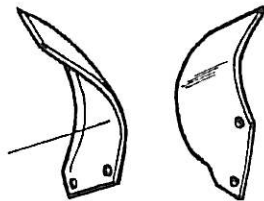

Fig. 8

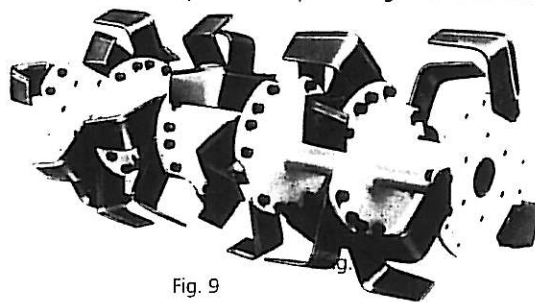

Fig. 9

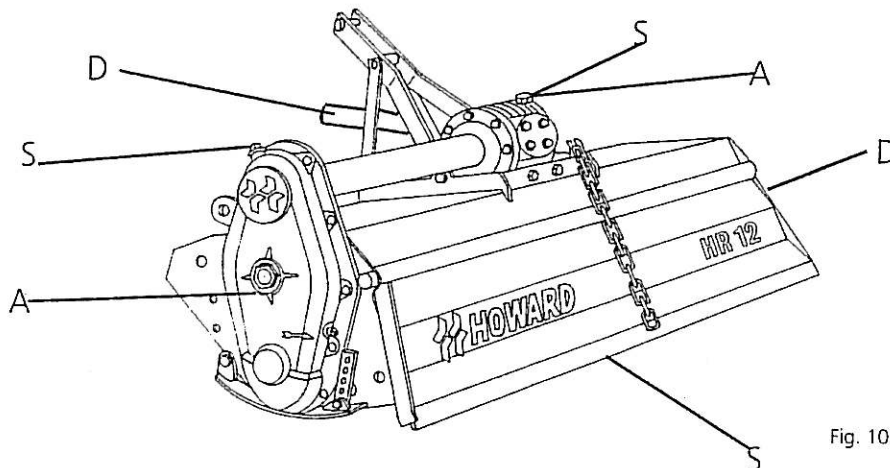

Fig. 10



**ATTENTION! IN ORDER TO OBTAIN A CORRECT MAINTENANCE AND FUNCTION OF YOUR MACHINE IS IMPERATIVE TO FOLLOW THE ENCLOSED INSTRUCTIONS:**

- **(D) DAILY:**
  1. Lubricate with grease gun PTO spiders.
  2. Lubricate with grease gun right hand stub axle bearing
- **(S) WEEKLY:**
  1. Top up with oil SAE 90 The gearbox.
  2. Top up with oil SAE 90 The side drive gearcase.
  3. Tighten fasteners.
- **(A) EVERY 500 WORKING HOURS:**
  1. Drain flush and fill with oil SAE 90 the gearbox.  
Drain flush and fill with oil SAE 90 the side drive gearcase.

# Rotavator

HR7 - HR7 HD - HR12

## OPERATING INSTRUCTIONS

### Operational information

By simple adjustments, HR7 / HR7 HD / HR12 Rotavators, will produce a range of tilths in most soil types to prepare the desired seedbed suitable to seed-drill requirements. As a general principle fine tilths are produced by a combination of slow tractor speeds and a lowered trailing board (fig.11). Conversely coarse tilths are produced by fast tractor speeds and a raised trailing board (fig.12).

Intermediate grades of tilth from coarse to fine can be obtained by:

- Adjusting the pressure on the trailing board which by impact shatters the blade cut "clods".
- Raising the trailing board which also deposit weeds and trash on the surface to wither .
- With the trailing board completely pressured trash is buried having a levelling effect on the soil.
- Increasing or decreasing the tractor speed will also affect the tilth.
- High working speeds may also be used for shallow work on previously broken ground.

### Working instructions

Set the depth control skids to the required tillage depth (page 16). Select a trial trailing board position to give the type of tilth required. Engage the tractor Pto and Drive forward progressively lowering the Rotavator into the ground. Proceed for a short distance and check whether the resultant tilth is satisfactory and the tillage depth is uniform across the rotor width. If not make the appropriate adjustments to obtain the required tilth.

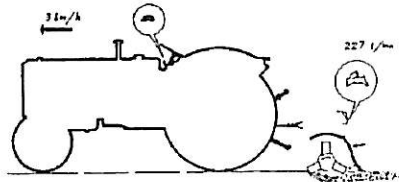

Fig. 11

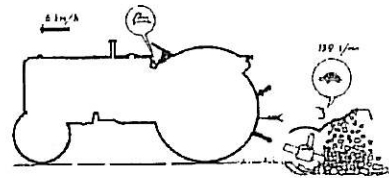

Fig. 12

# Rotavator

HR7 - HR7 HD - HR12

## OPERATORS CHECK LIST

### Insufficient depth obtained

- a) Adjust depth control skids
- b) Insufficient power: use a lower tractor gear
- c) Gearcase on hard soil. Further pass required
- d) Blades incorrectly mounted.

### Tilth too fine

- a) Raise the trailing board.
- b) Use a faster tractor gear

### Tilth too coarse

- a) Lower the trailing board
- b) Use a lower tractor gear
- c) Wait until soil is drier if sticks

### Blades "balling up" with soil

- a) Ground too sticky for working
- b) Raise trailing board
- c) Decrease tractor speed

### Excessive blade wear

- a) Replace loose or bent blades

### Rotavator "bumping" on ground

- a) Obstacles entangled in blades
- b) Blades incorrectly mounted with no scroll effect.
- c) Blades with blunt edge leading or broken blades

### Uneven depth

- a) Verify the skids and the tractor arms

### Working on hillsides

- a) Work up the slope if possible

### Advices

- The worked ground should always be to the right of the driver
- The field headlands should not be tilled until the "lands" have been completed



**THE ROTAVATOR SHOULD NEVER BE LOWERED WHILST THE TRACTOR IS TURNING**



# Rotavator

HR7 - HR7 HD - HR12

## WARNING AND DANGER SIGNALS

These signals are placed on the machine and they advise from warnings and potential dangers. Please follow the indication enclosed, and remember them when working with the Rotavator.



DO NOT WORK UNDER THE MACHINE UNLESS IT IS FIRMLY SUPPORTED.

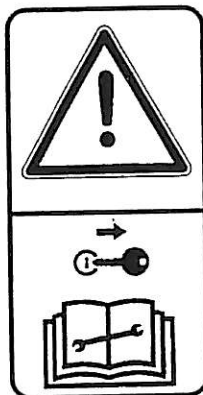

WARNING!: READ CAREFULLY THE INSTRUCTIONS. BEFORE HANDLING OR REPAIRING THE MACHINE REMOVE THE TRACTOR IGNITION KEY

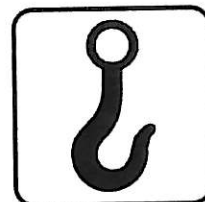

LIFTING POINT



DO NOT STAY ON THE ROTAVATOR WHEN TRANSPORTING NEITHER WORKING

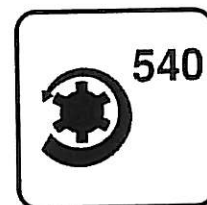

THE DRIVE IS BY A PTO FROM A 540 TPM TRACTOR PTO



STAY AT LEAST AT A DISTANCE OF 4 METERS WHEN THE ROTAVATOR IS RUNNING.



MAINTAIN HANDS AND FEET AWAY WHEN ROTAVATOR IS WORKING



DANGER! OBJECTS PROJECTION.



 **HOWARD**

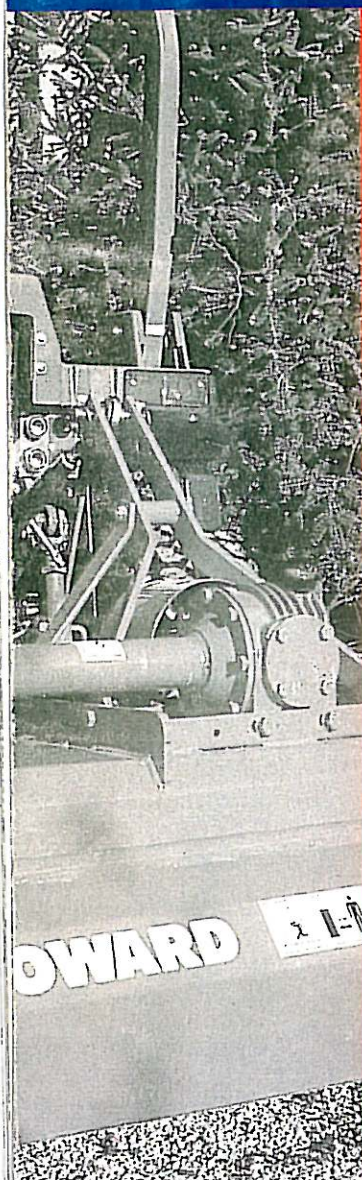

**HOWARD IBERICA, S.A.**

Ctra. Granollers a Girona, Km 1,5  
Apdo. 246  
08400 GRANOLLERS (BARCELONA) ESPAÑA

Tel.: (+34) 93 8492622  
(+34) 93 8617150  
Fax: (+34) 93 8493577 (Comercial - Sales)  
(+34) 93 8492031 (Recambios - Spareparts)

E-mail: [howard@howard.es](mailto:howard@howard.es)  
[www.howard.es](http://www.howard.es)